

SCOTTISH SCHOOLS SCIENCE

EQUIPMENT RESEARCH

CENTRE

Bulletin No. 16.

September, 1967.

Contents

Introduction		Page 1.
Opinion		1.
Physics Notes	- water barometer	2.
	- the velocity of light	3.
	- Brownian motion	5.
Trade News		6.
Chemistry Notes	- anodising aluminium	6.
In The Workshop	- a gas generator	7.
	- a binary adder/subtractor	9.
Supplement	- power supplies	11.
Address List		12.

Introduction

Teachers may not realise that the continued existence of the S.S.S.E.R.C. organisation depends wholly on the financial support of Scottish local education authorities. When our Governing Body have approved the estimates for the next financial year, each authority is informed of the amount it will have to contribute, a figure which depends directly on the secondary school population in the authority's control. The resulting sum, together with a much smaller amount subscribed by non-L.E.A. schools and manufacturers is our sole means of support. In reaching a decision on whether to continue their support of S.S.S.E.R.C., each Education Committee will be guided by its Director of Education who must rely on the informed opinion of his teachers. As our main contact with the great majority of teachers is our Bulletin, it could well be described as our lifeline.

It may not be generally known that one Scottish education authority, viz. East Lothian declined to enter the S.S.S.E.R.C. consortium when originally invited and has since twice confirmed its decision. Up to the present time, however, we have continued to send bulletins to their schools, and no East Lothian teacher has been refused help from or admission to the Centre. It is therefore with regret that I have to announce a decision by the Governing Body to discontinue the services which S.S.S.E.R.C. provides to East Lothian schools.

Opinion

In past issues I have used this section of the Bulletin in much the same way as the Editor of a Technical Journal may use his leader column to comment on some general aspect of the scientific field in which the Journal is interested. It is not for nothing that the section is headed 'Opinion', and it is expected and indeed hoped that the opinions therein expressed will conflict with those of some of our readers. If there is dust about, little ultimate good will come from sweeping it under the carpet, and to stimulate controversy may itself help to clear the air a little.

It came as no surprise therefore to be sharply rapped across the knuckles by both the administration and the profession when I commented on the shortage of Science Advisers in Scotland. On the other hand, I received a letter from a science adviser (English) commenting: "It is indeed extraordinary how many local authorities do not have science advisers and yet these same authorities have more than one adviser for some subjects such as art, housecraft, P.E., etc. It seems that the sooner we get more science Headmasters and administrators, the sooner we will get our priorities right." And before the furore descends on my head, I hasten to disassociate myself from that last opinion.

* * * * *

One aspect of the decision to convert all our schools to the comprehensive system of education at present under implementation by the local education authorities which has had little or no publicity, is its effect on the recruitment of teachers. To judge from the comments of those already in the profession it is hard to believe/

believe that this can be anything but harmful. Some teachers to whom I have talked have declared that under no circumstances would they teach in a comprehensive school; one or two I know have already forsaken the blackboard jungle for this very reason. I have found none to support the practice of comprehensive education, not even in the junior secondary schools. It may be hard to justify this attitude of the profession but it is a fact to be faced, if indeed our politicians can be brought to face any facts in the educational world. A disgruntled profession which believes that education has become the plaything of the politicians is a greater discouragement to the would-be teacher than any salary scale. When one considers the changes which have taken place in education in the past twenty years and are still taking place, one is reminded, sadly, of the story by Lord Dunsany of the village which had a hill between it and its view of the sea; and of the labourer who at different stages was decorated by both political parties for devoting the early part of his life to removing this hill, wheelbarrow by wheelbarrow, and his later years, in the changed political opinion, to putting it back again.

Physics Notes

The construction of an accurate water barometer is an impossible task because the final instrument will be temperature dependent, due to the vapour pressure of the water. To erect a water column which will show that the atmosphere will support over 30 ft or 11 m of water is not too difficult. The main requirement is one which is built into the school and in the absence of which the teacher can do nothing, viz, a convenient vertical height with at least three access points at top, bottom and somewhere in between. It is for this reason that we are giving a few hints on the process of erecting a barometer rather than a detailed description which would qualify for inclusion in our 'In The Workshop'.

There is an informative account of one such erection in the School Science Review for March, 1947, No. 105, p. 173, made more difficult than it need be by the use of a glass-to-metal seal. Three 10 ft lengths of slotted angle, Dexion or Handy Angle, can be butt-jointed end to end to provide a 30 ft long support for the glass tubing which is to form the barometer. Two short lengths - 25 to 30 cm - of the same angle will be needed to lap over the outer edge of the angle to form the joins between the main lengths, using at least four nuts and bolts to each join. When bolted together the whole forms a reasonably rigid support, to which 5 ft lengths of soda glass tubing, 5 mm inside diameter, can be tied. 5 cm lengths of Leibig condenser tubing, either rubber or plastic, can be used to join adjacent glass tubes for all except the top third of the barometer when pressure tubing is advisable. At each join the tubing should be pushed well home so that the gap between the glass tube ends is less than 1 cm.

Whether the assembly is done before or after erection of the barometer depends on the individual circumstances of the school. If a stair well is being used, erection and assembly will need to go hand in hand, the pieces of glass tubing being fixed as each length of slotted angle is secured against the banister rails. It should be borne in mind that, depending on the size of angle used, the weight of the support can be from 12 - 20 kgf (27 - 44 lbf) and that the method of fixture to the permanent fittings of the school, as well as those fittings themselves, must be capable of bearing this load. If a flat roof to the building is to be used as the top access point, and provided it is of adequate size, the barometer can be completely assembled on the horizontal, thereafter lowering the/

the whole into position. In the case of an outside erection such as this, short lengths of slotted angle horizontally screwed to window ledges and accessible through the windows, can be used as intermediate supports for the column, although they should not be regarded as weight-bearing members.

In the hope that the final 'vacuum' achievable will be good enough to show a head of water greater than the 30 ft length of the slotted angle, the lower end of the support should be fixed to some framework which keeps it at 100 - 150 cm above the ground or base level, using a short length of glass tube to connect the remainder to the reservoir. This can conveniently be an aquarium tank; the main requirement is for an opening large enough to allow both hands to work under the water surface.

Filling is done from the top. An aspirator containing coloured water, boiled if this be thought desirable to remove as much dissolved air as possible is connected via rubber tubing which carries a screw and a pinch clip to the barometer top. A similar length of tubing also fitted with a pinch clip is fixed to the bottom, the whole of course being under the reservoir surface. After the top clips have been opened control is largely exercised by the individual at the bottom who must allow the liquid to rush through at a speed great enough to carry down any air bubbles formed in the tube, but not so fast that he cannot shut off the flow before the aspirator has emptied, a fact of which he must be warned by his top colleague. Between 1 and 2 l of water in the aspirator should be sufficient. When the column is full, both clips on the tubing at the top are closed, the aspirator is removed, followed by the rubber tubing at the bottom. No matter how prolonged the boiling of the water has been, some air bubbles will appear and slowly rise to destroy whatever vacuum has been produced, so that a final height of 10 m or over can be regarded as satisfactory. In the weeks following, the level will gradually fall as more air comes out of solution or possibly leaks out from that trapped in the joints of the glass tubing.

* * * * *

Some physics teachers, looking ahead to the post-Higher syllabus with its requirement that the student shall produce a report of a project or projects which he has carried out, may be interested in the possibilities of using a laser in this work. There seems little doubt that the laser will eventually feature as a piece of school apparatus, and the Scottish Education Department are at the moment considering whether there is a need for a code of practice in the use of lasers in school in order to ensure the safety of those handling the equipment. The helium-neon gas laser, which is the only type likely to be used in schools operates at the comparatively low power level of 1 mW or less and there would appear to be small risk of retinal damage when looking at the laser beam. In the factory, the mirrors are aligned by workers sighting down the beam itself, albeit through a tiny hole which would nevertheless transmit more than a quarter of the total beam intensity. These employees have regular medical inspection of the retina without there having been so far any evidence of damage.

The purpose of this note is to give some indication to teachers of the possibilities in using a laser beam to determine the velocity of light, using only such auxiliary equipment as may be found or easily constructed in the school. At the outset it should be said that we have not yet succeeded in the experiment, but that the

(4)

variable frequency from a signal generator and to detect the phase difference by a Lissajou figure ellipse between the transmitted beam and that reflected from a distant mirror. For a 90° phase difference the ellipse on the oscilloscope will have its axes horizontal and vertical, and as this is more readily determined than the angle of a tilted ellipse (except possibly the one for 45° phase shift), it would seem desirable to adjust the modulation frequency until the upright ellipse was achieved and then to determine from the frequency what the quarter period, which is the to-and-fro time of the beam, would be.

In the Centre we have only one convenient reflecting point, which is a schoolroom at the other end of the block, some 180 m distant. A quick calculation will show that to achieve 90° phase shift over a 360 m path, a modulation frequency of the order of 200 kHz is required. It is the difficulty of achieving sufficient depth of modulation at this frequency and/or that of sufficient amplification on the detecting system which has so far limited our success in the experiment. The laser used was a Ferranti type SL4 which has now been superseded by a later version, the GP2, which we have only briefly seen. As far as can be determined from the manufacturer's literature, however, the modulation systems are the same.

At the receiving end the beam was focused on an OCP71 photo-transistor, used in the circuit shown below.

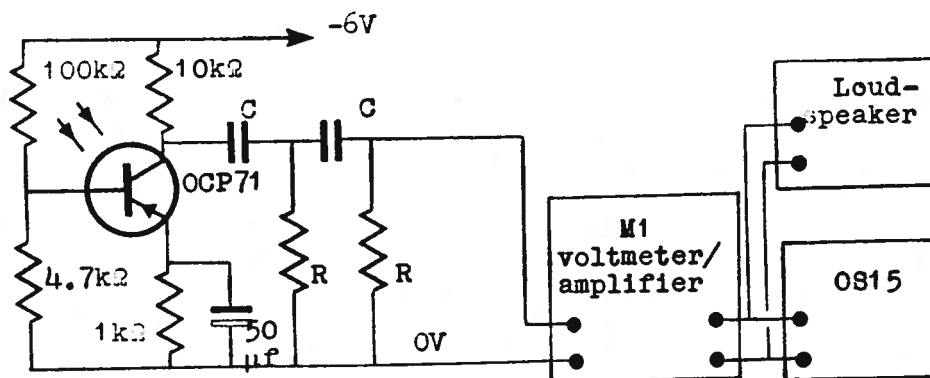

The received signal on the transistor consists of the required modulation frequency together with a much larger amplitude signal of very low frequency due to the vibrations of the buildings in which the transmitter and reflecting mirror are housed. The CR filter following the transistor is used to remove this unwanted signal; the values of C and R will depend on the modulation frequency being used. The Linstead transistorised voltmeter is basically used as an amplifier with a specified gain of $\times 80$, but it was also convenient for indicating the amplitude of the modulating signal. At 5 kHz this showed an amplitude of 15 mV on the transmitted, and 2.5 mV on the reflected beam, giving a reduction in intensity through the optical system of 6 : 1.

Modulation was supplied by an Advance J2 signal generator, which has a maximum frequency of 50 kHz and would have to be replaced by one of higher frequency in the later stages of the experiment. If the output is turned above 35 V the modulation tends to extinguish the beam. Although the modulation depth can be increased by reducing the HT current, again below 10 mA the beam tends to be extinguished. Also the GP2 laser has no facility for varying the HT current. The depth of modulation achievable varies inversely with the frequency and even at 50 kHz we have just been able with the amplification described above to detect modulation on the transmitted beam with the oscilloscope, which was an Advance OS15, at full gain. We are proceeding with the construction and use of higher gain amplifiers to see whether modulation is possible at/

at, say 100 kHz. Another problem which has still to be examined is that there is evidence of 2nd or 3rd harmonic distortion on the transmitted beam, which if large enough would produce kinks on the ellipse and make it difficult to determine its degree of uprightness.

The optical system was surprisingly simple. The quoted divergence of the laser beam of 0.77 milliradian would have given a spot some 15 cm diameter on the reflecting mirror, so a standard bi-convex lens of 100 cm focal length was used, reducing the divergence by a factor of 6 at its best adjustment. A plane mirror reflector, again a standard item, was used at the distant end and the beam was finally focused on the photo-transistor by a 18 x 25 cm plastic Fresnel lens, type MG-100-1 purchased from Sound and Science for 8s.6d. We estimate that it would be possible to use the same optical system and extend the path length to twice its present one.

Location and alignment of the beam presented difficulties, but they were largely those of communication since only one member of the staff knew semaphore and it was impossible to run telephone cables across the gardens of the intervening houses. All setting up was done in normal working hours, and although of necessity the experiments were carried out during the summer holiday when there were no schoolchildren in the room at the reflecting end, there was an army of cleaners and workmen curious to know what was taking place so that re-alignment usually had to be done every day. In the preliminary stages alignment was done by looking down the beam from the far end, but after some focusing had been achieved it was possible with the dim-out produced in the classroom by drawing the blinds to catch the beam on a white screen. At the Centre, both transmitter and receiver were placed in our "darkroom", the door of which had to be kept open for transmission and reception of the beam. The final focused spot was irregular in shape, probably due to distortion of the plane mirror produced by holding it in a clamp, but its most intense part was no larger than that of the transmitted beam.

In conclusion we think that there are no insuperable difficulties in transmitting and reflecting a laser beam over a path length of 500 - 600 m with normal school equipment, possibly even longer. Whether the modulation problem will prove equally amenable to a solution remains to be seen.

* * * * *

In common with many teachers we have thought it very desirable to be able to show the effect of temperature on molecular movement (or vice versa, depending on the point of view), using a Brownian motion cell. To this end a smoke cell was constructed using a brass block 80 x 30 x 15 mm, in the centre of which was a small chamber which was open at the top for viewing, being sealed with a glass cover slip, and at one side to admit a light beam introduced through a glass rod. An electrical heating element was incorporated, and the chamber could thus be heated to about 200°C, after which a heat balance with the air was achieved. The results were disappointing; during heating or cooling convection made observation impossible. At the high temperature it appeared - and this must necessarily be a subjective view - that the smoke particles had in fact decreased their activity.

It may be that since the motion of a smoke particle depends on an imbalance of bombardment from different directions, the increased molecular motion at the higher temperature has 'evened out' the

oil. At 20°C no movement can be seen, but at 100°C Brownian movement is clearly visible. For this experiment a block can be steam heated by using a hole drilled lengthwise through it. It is unfortunate that the microscope objective must be in such close proximity to the slide that the viewing time is restricted, otherwise the heat may crack the objective lens. This experiment at least gives partial success, and ~~it~~ it is claimed that the motion is not a 'true' one but results from the reduced viscosity of the oil, is not this begging the question? Can it not be argued that the viscosity/temperature dependence is itself evidence for the kinetic theory?

Trade News

Price changes have taken place on Avo multi-range meters. The Model 7 now costs £21; the Model 8 £22. 10s. and the Multi-minor £7. 12s. 6d. Elesco-Fraser are sole agents for Avo products in Scotland.

The firm of Cottrell and Co., whom we gave in Bulletin 14 as a source of dental X-ray film suitable for radiographs, have changed their address. The new address is given in the address list to this Bulletin.

Small Nife cells of 3 ampere-hour capacity are available for 5s.6d each, post 3s., or 10 cells for £2. 10s. post 7s.6d., from Arthur Sallis. The supply is limited to about 2500. The only other source which we know of these extremely useful items is Service Trading Co. (see Bulletin 10).

Butterworths (Edinburgh) are agents for Japanese Myacope stereomicroscopes. The model KSS, magnification x8 is ideal for use as a dissecting microscope and costs £12. The model KTSG can be had with magnifications of x10, x20, x40, or x60. Price with any one objective £39; extra objectives cost £3. 3s. or £5. 5s.

J. A. Radley are offering radio-active isotopes in 300 mg tablet form for use in chemical and biological experiments. Isotopes available are silver 110, carbon 14, sulphur 35, sodium 22, iron 59, calcium 45, iodine 131, and phosphorus 32. These are available ex stock, apart from the last two which have short half-lives and for which the firm require advance notice. Activities vary, but teachers are reminded that these sources come under the conditions of supply and tenure set out in Bulletin 14, p.3. Each isotope is associated with a tablet carrier containing the same stable element in compound form. Cost is 10s. per tablet, with 4s. minimum postal charge.

Chemistry Notes

Anodising aluminium is perhaps as popular with the school's technical department as it is with chemistry teachers, if the proliferation of ash trays seen on open days is any guide. The Aluminium Federation will supply an anodising kit with notes to any school for a nominal 5s. charge. Recently these kits have proved so popular that to maintain demand and keep costs down, the Federation are to reduce the variety of dyes supplied, but to increase the quantity of each. In addition the sealer, which is only required for a professional job and not for demonstrating the principle, is being/

being omitted.

Although there is no doubt that the kit is a bargain at the price, the procedures and materials used in the process are simple enough for any school to carry out a successful demonstration. The chemicals required are:

Degreaser	carbon tetrachloride; <i>111 trichloroethane</i>
Etchant	approx. 1 l normal sodium hydroxide solution;
Neutraliser for etchant	same quantity normal nitric acid;
Electrolyte	250 ml conc. sulphuric acid, diluted to make 2 l solution;
Dyes	Dylon No. 9 red, 1 g in 500 ml water; Dylon No. 16 blue, 1 g in 1 l water; these dyes are available from local ironmongers;
Sealer	5 g nickel acetate and 5 g boric acid in 1 l water;
Cathode	aluminium sheet;
Support jig	aluminium wire.

The workpiece is wiped with carbon tetrachloride and must thereafter be handled only on its edges, and as little as possible. For preference the aluminium wire jig should be twisted round the workpiece to form a support and the electrical contact before degreasing. The support should touch the work only at the edges. To ensure that the surface is thoroughly clean, the work is then dipped in warm etchant until effervescence occurs, followed by rinsing, dipping in cold neutraliser and another rinse. These steps may be omitted by anyone wishing only to demonstrate the principle.

The cathode is bent round until it forms an almost complete cylinder, and the work is suspended inside, the whole being immersed in electrolyte. To avoid the very high initial current surge the power supply control must be increased slowly to a potential of 12V. The current density to be expected is of the order of 10 - 15 mA per cm² of work surface, both sides of the surface being reckoned. The temperature of the electrolyte should be between 20 and 25°C, and approximately 30 minutes running time is required.

The work is then rinsed and immersed for 3 - 5 minutes in hot dye - temperature 65 to 75°C - followed by another rinse. The dye is fixed in the anodic film by boiling in the sealing solution for 15 minutes, although for demonstration the dye itself may be brought to the boil for a similar period. Finish by rinsing, wiping and drying. Provided that the solutions have been prepared in advance the complete process need take no more than one hour. A pictorial account of the process is given in Chemistry Takes Shape, Book 3, p.41, Johnstone and Morrison, Heinemann.

In The Workshop

A pupil gas generator for hydrogen or carbon dioxide can be made from two plastic detergent bottles. The generator is not suitable for hydrogen sulphide or other noxious gas since any excess generated by the last user will escape to the atmosphere. The lower bottle holds the acid and is used without adulteration, simply fitting a convenient size of glass tube, covered by P.V.C. tubing in the neck of the bottle. If the P.V.C. tube is some 5 mm longer than the glass, and overlaps it at the top, the end of the glass tube forms a/

a natural ledge to take a grid which will filter out large particles of the solid reagent and prevent them from dropping into the acid. It is important not to insert the P.V.C. and glass tube too far into the neck of the upper container, as this would then trap some acid and cause continuous generation of gas.

The second detergent bottle is reduced in size by cutting out the central ring section in order to leave top and bottom sections which are about 6 cm in depth. These are then pushed one inside the other to form a smaller container. If the inner of the two halves is cut with a serrated edge, this makes for easier insertion. This reduction in size would not be necessary if one could find a shorter plastic bottle with the same size of neck as the lower bottle; our own version was made from two Squezy bottles.

A circular hole using a heated No. 8 cork borer (see Bulletin 13, p.8 for details of cutting holes in polythene) is cut centrally in the base of the bottle to take a No. 13 single-holed rubber stopper carrying a right angle tube. The limbs of this tube need not be more than 5 cm long. A Bunsen valve (see below) is fitted to the exit end of the tube and the whole is covered by a delivery tube made from a short length of glass tubing, 11 mm inside diameter drawn out to a delivery jet at one end, and fitting a No. 11 stopper. This tube also gives protection to the Bunsen valve.

The Bunsen valve is made from a 2 cm length of rubber, P.V.C., or polythene tubing blocked at one end with a glass bead or stub of glass rod. A single, clean cut extending to about one third of the tube diameter is made diagonally with a new razor blade. Under excess pressure from inside, the valve will open, but when the pressures are equalised the natural elasticity aided by the weight of the glass bead, if the tube is mounted with the cut on the under side, will close the valve. The grid which separates the bottles is cut from the discarded section of the upper bottle, using cork borer as before, and piercing several holes in it with a hot wire. To use the generator, squeeze the lower container when gas is forced out through the delivery tube and simultaneously the acid is brought into contact with the solid reagent in the upper vessel.

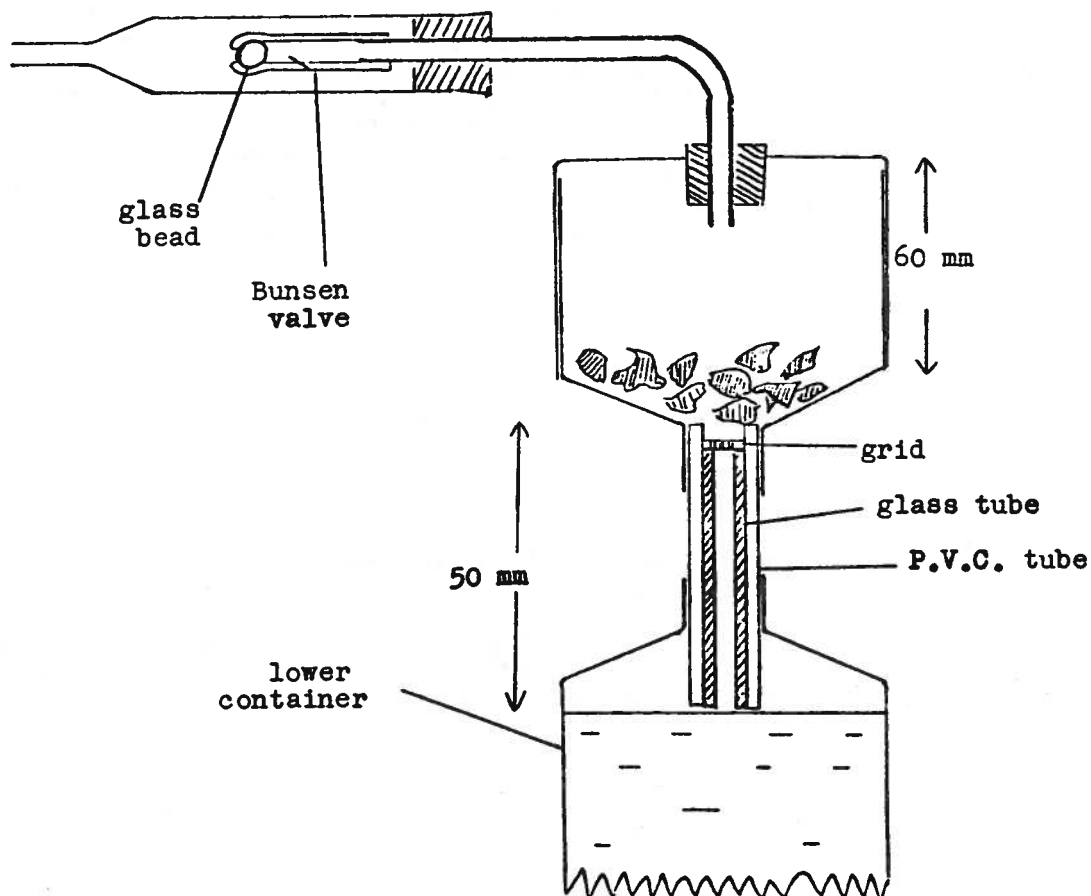

The design for the binary adder/subtractor given below was copied from a model shown by the B.B.C. on their stand at the A.S.E. conference at Nottingham last year. After being put on display at the Centre, it aroused some interest among physics teachers, to an extent that they persuaded their mathematics colleagues to come and see it. They being equally impressed, we felt it worthy of publication here. To any school doing the new mathematics syllabus, we would suggest that the science departments might show the design to their mathematics staff, in case they are interested.

The design which performs the functions of counting on the binary scale, and subtraction by reading the complements, is that of a bi-stable mechanical flip-flop, and is operated by rolling marbles down a slope. The marble triggers each flip-flop into the opposite stable state. Guides on one side of the design deflect the marbles out of the system once they have operated on the highest order in use with a particular number. Two examples will serve to indicate the action. Referring to Diagram 1, ABC and DEF are two consecutive flip-flops, pivoting about P and Q respectively. As drawn in the diagram both flip-flops are registering zero for addition (or $11 = 3$ for subtraction).

When a marble is rolled down in the direction of the arrow, it trips the first flip-flop into position A'B'C' as it rolls along the leg PC. The deflector guide XYZ, which is pinned into position on the base board then moves the marble to the right hand side whence it drops out of the system, thus avoiding the first order flip-flop DEF. Pointer PB is now indicating right (= 1 for addition or 0 for subtraction) so that the complete system shows 01 for addition or $10 = 2$ for subtraction. Stops are provided to limit the angle of tilt of the flip-flop to 60° either side of the vertical.

If a second marble is now used it rolls along B'PA', tripping the switch to its opposite state, and is then passed by leg PA' into EQF, which is also tripped into its opposite state with QE pointing right. Thereafter a similar deflector guide moves the marble out of the system. The position now is that QE points right (indicating 1 on addition, or 0 on subtraction) and PB is back in its original position. The system therefore reads $10 = 2$ for addition or $01 = 1$ for subtraction. Thus rolling two marbles down has added 2 to 0 or has subtracted 2 from 3. The rule therefore is that to add or count on the binary scale, left indicating pointers are reckoned 0 and right indicating pointers are reckoned 1, while the reverse is used when subtracting.

Figure 2 gives the layout of a single order and is drawn full-scale. The flip-flops are made from an 18 mm wide strip of 18 SWG aluminium. The deflectors are made from a similar width of 22 SWG brass. Panel pins are soldered to the bend and lower end of each deflector to allow them to be push-fitted into previously drilled holes in the plywood baseboard, which measures 77 mm wide x 12 mm thick. A 54 cm length of this will accommodate eight flip-flops, allowing a count of up to $2^7 = 128$. A nail, push-fitted into a drill hole, acts as a pivot for each flip-flop, and a 6 BA washer is used between baseboard and switch to give freedom of movement. Panel pins are also used for the right hand stops. Two vertical strips of the same aluminium sheet are screwed to the sides of the baseboard to prevent the marbles from straying off the board. That on the left hand side also acts as the stop for the flip-flop, while the right hand one must give a clearance of 17 mm to provide a drop-out channel for the marbles which have finished operating the switches. On our own design the top ply of wood was also lifted out for this channel, as this will prevent a marble from possibly straying back into the system when it shouldn't which might happen if the bench

The distance between pivots in successive orders is 55 mm.

In our design, the baseboard was mounted at a slope of 20° on a wooden base, with a drop-out box to catch the spent marbles at the bottom. One or two teachers have suggested that it would be a comparatively simple matter to electrify the counter by connecting the right hand panel pin stops to lamp bulbs, completing the circuit through the central pivot of the switch. Without considering the merits of this proposal - and we think one of the most appealing features of the design is its simplicity - we would expect some trouble over the connection between pivot and switch. This must be comparatively free to allow it to be operated by the small momentum of the marble, and it is likely therefore that it will have a high resistance contact and give trouble when lighting lamp bulbs. The aluminium is also rather light so that the pressure with which it bears against the stop will be minimal, with again the possibility of a high resistance contact. All in all, we doubt if it is worth the teacher's trouble. As an open-ended project, if suggested by an enthusiastic pupil, this would be a different matter.

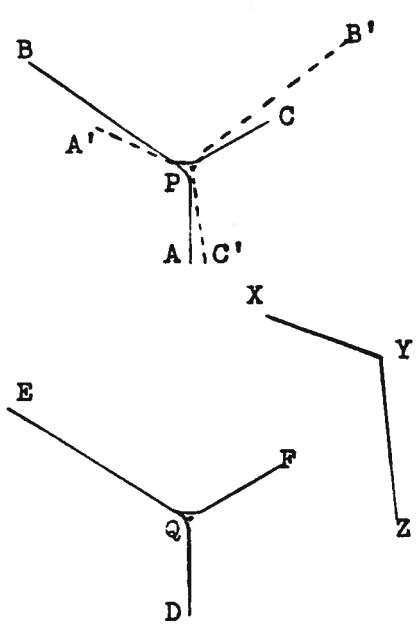
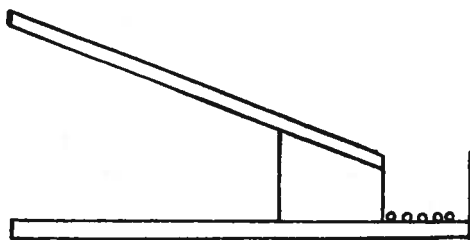

Fig. 1.



Elevation

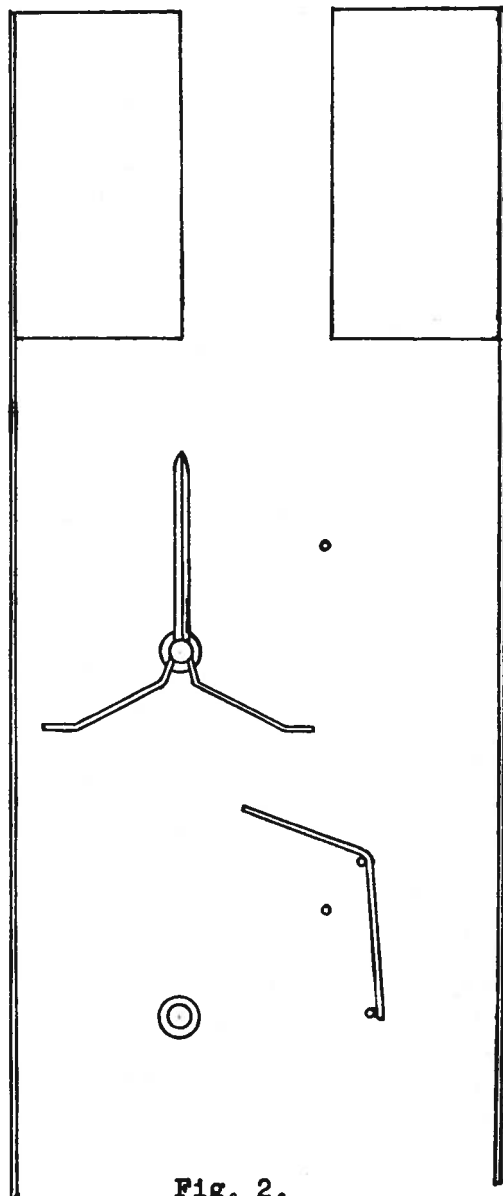

Fig. 2.

Bulletin Supplement

As intimated in our last Bulletin, we give below the second half of the summary on the reports on E.L.T. power supplies. Individual reports on these models can be borrowed for up to one month by writing to the Director. The classifications used are: A - most suitable for school use; B - satisfactory for school use; C - unsatisfactory.

Cat. No.	022.311	022.312	K95/1520
Supplier	Unilab	Unilab	W. B. Nicolson
Price	£4	£4	£5. 18s.
Outputs at zero current	A.C. 2.45V A.C. 1.24V D.C. 1.10V	2.20V 1.12V 0.95V	2.25V 1.10V 0.98V
Outputs at 5 amps	A.C. 2.00V A.C. 1.04V D.C. 0.55V	1.76V 0.90V 0.43V	2.04V 1.03V 0.51V
Outer Case	plastic unventilated unearthed	plastic unventilated unearthed	metal with plastic top unventilated unearthed
Stacking ability	bad	bad	bad
Assessment	A	A	B

Note: 022.311 is designed for 12V A.C. input; 022.312 is the same unit for 240V mains input.

SSERC 24 BERNARD TERRACE EDINBURGH RH8 9NX 031-668 442
~~S.S.S.E.R.C., 103 Broughton Street, Edinburgh, 1. Tel. WAV 2184.~~

Advance Electronics Ltd., Roebuck Road, Hainault, Ilford, Essex.

Aluminium Federation, Portland House, Stag Place, London, S.W.1.

Avo Ltd., Avocet House, Dover, Kent.

Butterworth's (Edinburgh) Ltd., London Road, Meadowbank, Edinburgh, 7.

Cottrell and Co. Ltd., 104/6 Hanover Street, Edinburgh, 2.

Dexion Ltd., 2/4 Empire Way, Wembley Park, Wembley Middlesex.

Elesco-Fraser Ltd., 36 St. Vincent Crescent, Glasgow, C.3.

Ferranti Ltd., King's Cross Road, Dundee.

Handy Angle Ltd., Reparco Works, Hamilton, Lanarkshire.

Linstead Electronics Ltd., 35c Newington Green, London, N.16.

W. B. Nicolson Ltd., Thornliebank Industrial Estate, Glasgow.

J. A. Radley Ltd., 220/222 Elgar Road, Reading, Berks.

Arthur Sallis Ltd., 93 North Road, Brighton, Sussex.

Sound and Science Ltd., 3-5 Eden Grove, Holloway, London, N.7.

Unilab Division, Rainbow Radio Ltd., Mincing Lane, Blackburn,
Lancs.